

1.25G TX1310RX1550**Product Features**

- Single LC receptacle optical interface compliant
- Hot-pluggable SFP footprint
- 1310nm DFB laser transmitter
- 1550nm APD Receiver
- RoHS compliant and Lead Free
- Up to 40km on 9/125um SMF
- Metal enclosure for lower EMI
- Single 3.3V power supply
- Low power dissipation <700mW
- Commercial operating temperature range: 0°C to 70°C

Applications

- Gigabit Ethernet
- 1.06 Gb/s Fibre Channel

General

Small Form Factor Pluggable (SFP) transceivers are compatible with the Small Form Factor Pluggable Multi-Sourcing Agreement (MSA). They simultaneously comply with Gigabit Ethernet as specified in IEEE STD 802.3 and 1x Fibre Channel as defined in FC-PI-2 Rev. 10.0 .They are RoHS compliant and lead-free.

I. Pin Descriptions

Pin	Symbol	Name/Description	Ref.
1	VeeT	Transmitter Ground (Common with Receiver Ground)	1
2	TX Fault	Transmitter Fault	
3	TX Disable	Transmitter Disable. Laser output disabled on high or open.	2
4	MOD_DEF(2)	Module Definition 2. Data line for Serial ID.	3
5	MOD_DEF(1)	Module Definition 1. Clock line for Serial ID.	3
6	MOD_DEF(0)	Module Definition 0. Grounded within the module.	3
7	Rate Select	No connection required	
8	LOS	Loss of Signal indication. Logic 0 indicates normal operation.	4
9	VeeR	Receiver Ground (Common with Transmitter Ground)	1
10	VeeR	Receiver Ground (Common with Transmitter Ground)	1
11	VeeR	Receiver Ground (Common with Transmitter Ground)	1
12	RD-	Receiver Inverted DATA out. AC Coupled	
13	RD+	Receiver Non-inverted DATA out. AC Coupled	
14	VeeR	Receiver Ground (Common with Transmitter Ground)	1
15	VccR	Receiver Power Supply	
16	VccT	Transmitter Power Supply	
17	VeeT	Transmitter Ground (Common with Receiver Ground)	1
18	TD+	Transmitter Non-Inverted DATA in. AC Coupled.	
19	TD-	Transmitter Inverted DATA in. AC Coupled.	
20	VeeT	Transmitter Ground (Common with Receiver Ground)	1

Notes:

1. Circuit ground is internally isolated from chassis ground.
2. Laser output disabled on TX Disable >2.0V or open, enabled on TX Disable<0.8V.
3. Should be pulled up with 4.7k - 10kohms on host board to a voltage between 2.0V and 3.6V. MOD_DEF(0) pulls line low to indicate module is plugged in.
4. LOS is LVTTTL output. Should be pulled up with 4.7k – 10kohms on host board to a voltage between 2.0V and 3.6V. Logic 0 indicates normal operation; logic 1 indicates loss of signal.

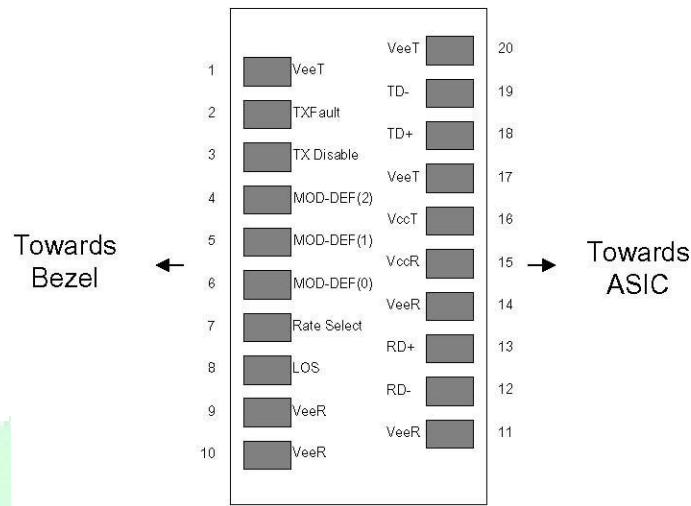

Pinout of Connector Block on Host Board

II. Absolute Maximum Ratings

Parameter	Symbol	Min	Typ	Max	Unit	Ref.
Maximum Supply Voltage	Vcc	-0.5		4.0	V	
Storage Temperature	TS	-40		100	°C	
Case Operating Temperature	TOP	0		70	°C	
Relative Humidity	RH	0		85	%	1

III. Electrical Characteristics (TOP=25°C, Vcc=3.3Volts)

Parameter	Symbol	Min	Typ	Max	Unit	Ref.
Supply Voltage	Vcc	3.00		3.60	V	
Supply Current	Icc			300	mA	
Transmitter						
Input differential impedance	Rin		100		Ω	2
Single ended data input swing	Vin, pp	250		1200	mV	
Transmit Disable Voltage	VD	Vcc – 1.3		Vcc	V	
Transmit Enable Voltage	VEN	Vee		Vee+ 0.8	V	
Transmit Disable Assert Time				10	us	
Receiver						
Single ended data output swing	Vout, pp	300	400	800	mV	3
Data output rise time	tr			300	ps	4
Data output fall time	tf			300	ps	4
LOS Fault	VLOS fault	Vcc – 0.5		VccHOST	V	5
LOS Normal	VLOS norm	Vee		Vee+0.5	V	5
Deterministic Jitter Contribution	RXΔDJ			80	ps	6
Total Jitter Contribution	RXΔTJ			122.4	ps	

Notes:

1. Non condensing.
2. AC coupled.
3. Into 100 ohm differential termination.
4. 20 – 80 %
5. LOS is LVTTTL. Logic 0 indicates normal operation; logic 1 indicates no signal detected.
6. Measured with DJ-free data input signal. In actual application, output DJ will be the sum of input DJ and ΔDJ.

IV. Optical Characteristics (TOP=25°C, Vcc=3.3 Volts)

Parameter	Symbol	Min	Typ	Max	Unit	Ref.
Transmitter						
Output Opt. Power	PO	0	-	+5	dBm	1
Optical Wavelength	λ	1290	1310	1330	nm	2
Spectral Width	σ	-	-	1	nm	2
Optical Rise/Fall Time	tr/tf	-	170	260	ps	4
Deterministic Jitter Contribution	TX Δ DJ	-	20	56.5	ps	5
Total Jitter Contribution	TX Δ TJ	-	-	227	ps	
Optical Extinction Ratio	ER	9	-	-	dB	
Receiver						
Average Rx Sensitivity @ 1.25 Gb/s (Gigabit Ethernet)	RSENS2	-	-	-32	dBm	6, 7
Average Rx Sensitivity @ 1.06 Gb/s (1X Fibre Channel)	RSENS1	-	-	-33	dBm	6, 7
Maximum Received Power	RXMAX	-9			dBm	
Optical Center Wavelength	λ C	1530	1550	1570	nm	
LOS De-Assert	LOSD	-	-	-34	dBm	
LOS Assert	LOSA	-45	-	-	dBm	
LOS Hysteresis		0.5	-	-	dB	

Notes:

1. Class 1 Laser Safety.
2. Also specified to meet curves in FC-PI-2 Rev. 10.0 Figure 18, which allow trade-off between wavelength, spectral width.
3. Equivalent extinction ratio specification for Fibre Channel. Allows smaller ER at higher average power.
4. Unfiltered, 20-80%. Complies with IEEE 802.3 (Gig. E) and FC 1x eye masks when filtered.
5. Measured with DJ-free data input signal. In actual application, output DJ will be the sum of input DJ and Δ DJ.
6. Measured with conformance signals defined in FC-PI-2 Rev. 10.0 specifications.
7. Measured with PRBS $2^7 - 1$ at 10^{-12} BER.

V. General Specifications

Parameter	Symbol	Min	Typ	Max	Units	Ref.
Data Rate	BR	1062		1250	Mb/sec	1
Bit Error Rate	BER			10^{-12}		2
Max. Supported Link Length on 9/125 μ m SMF @ 1x Fibre Channel	LMAX1			40	km	3, 4
Max. Supported Link Length on 9/125 μ m SMF @ Gigabit Ethernet	LMAX2			40	km	3, 4

Notes:

1. Gigabit Ethernet and 1x Fibre Channel compliant.
2. Tested with a PRBS $2^7 - 1$ data pattern.
3. Dispersion limited per FC-PI-2 Rev. 10
4. Attenuation of 0.25 dB/km is used for the link length calculations. Please refer to the Optical Specifications in Table IV to calculate a more accurate link budget based on specific conditions in your application.

VI. Environmental Specifications

Commercial Temperature BIDI SFP transceivers have an operating temperature range from 0°C to +70°C case temperature.

Parameter	Symbol	Min	Typ	Max	Units	Ref.
Case Operating Temperature	Top	0		70	°C	
Storage Temperature	Tsto	-40		100	°C	

VII. Mechanical Specifications

Small Form Factor Pluggable (SFP) transceivers are compatible with the dimensions defined by the SFP Multi-Sourcing Agreement (MSA).

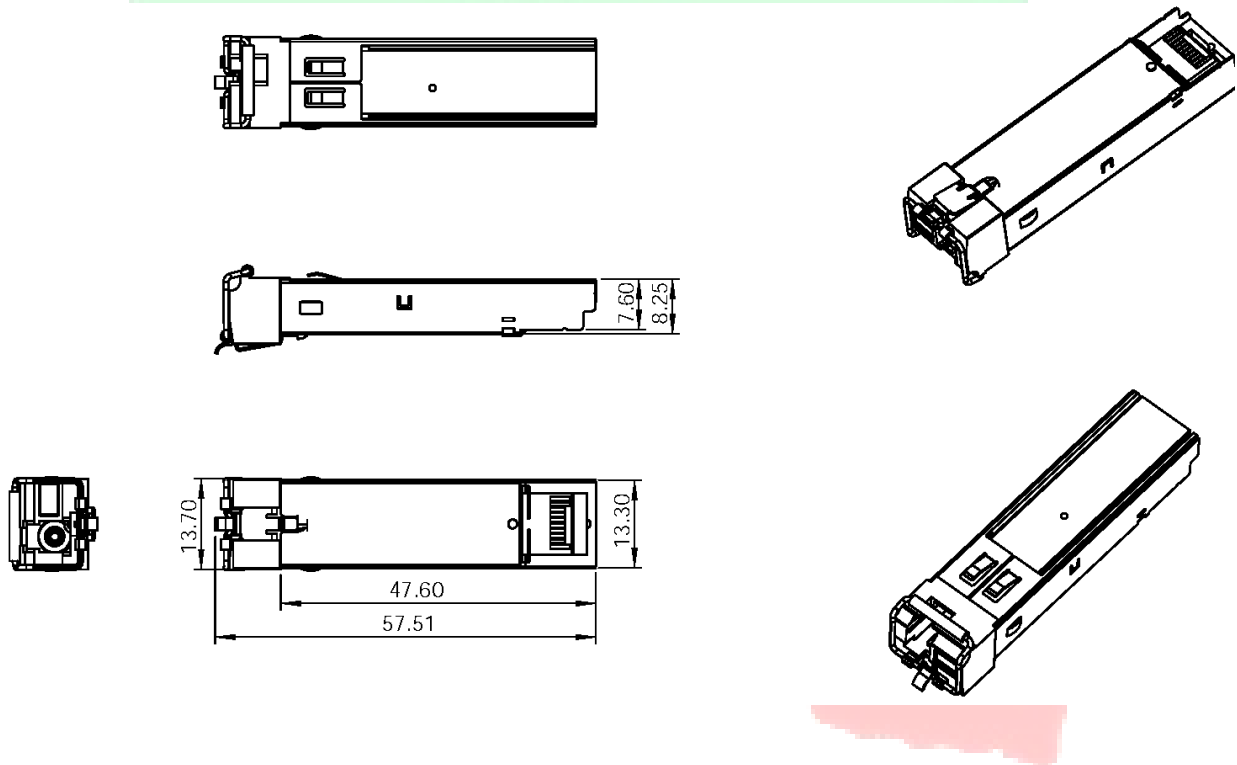

1.25G TX1310RX1550 40KM

IX. PCB Layout and Bezel Recommendations

- ▷ Datum and Basic Dimension Established by Customer
- ◁ Rads and Vias are Chassis Ground, 11 Places
- ▷ Through Holes are Unplated

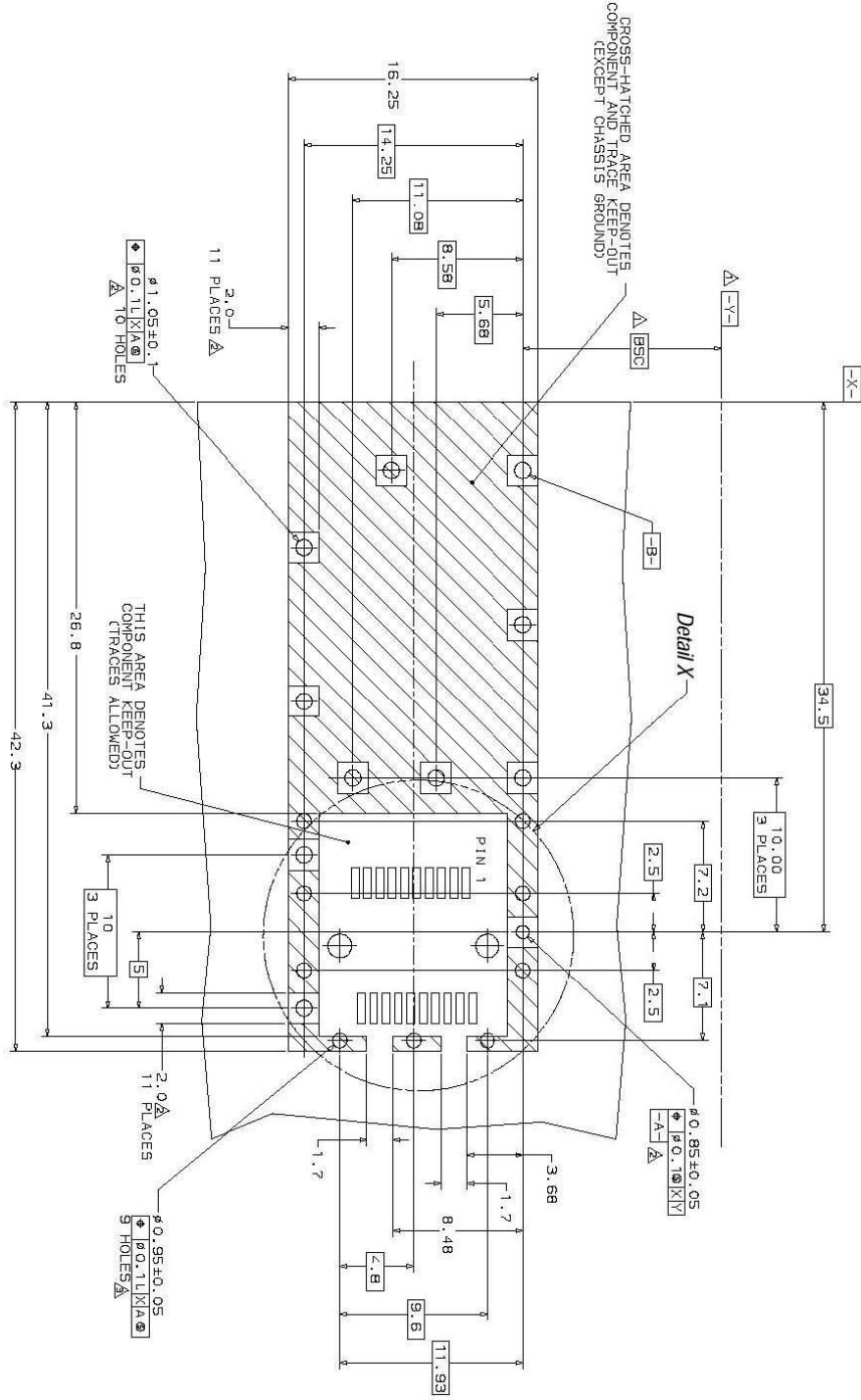

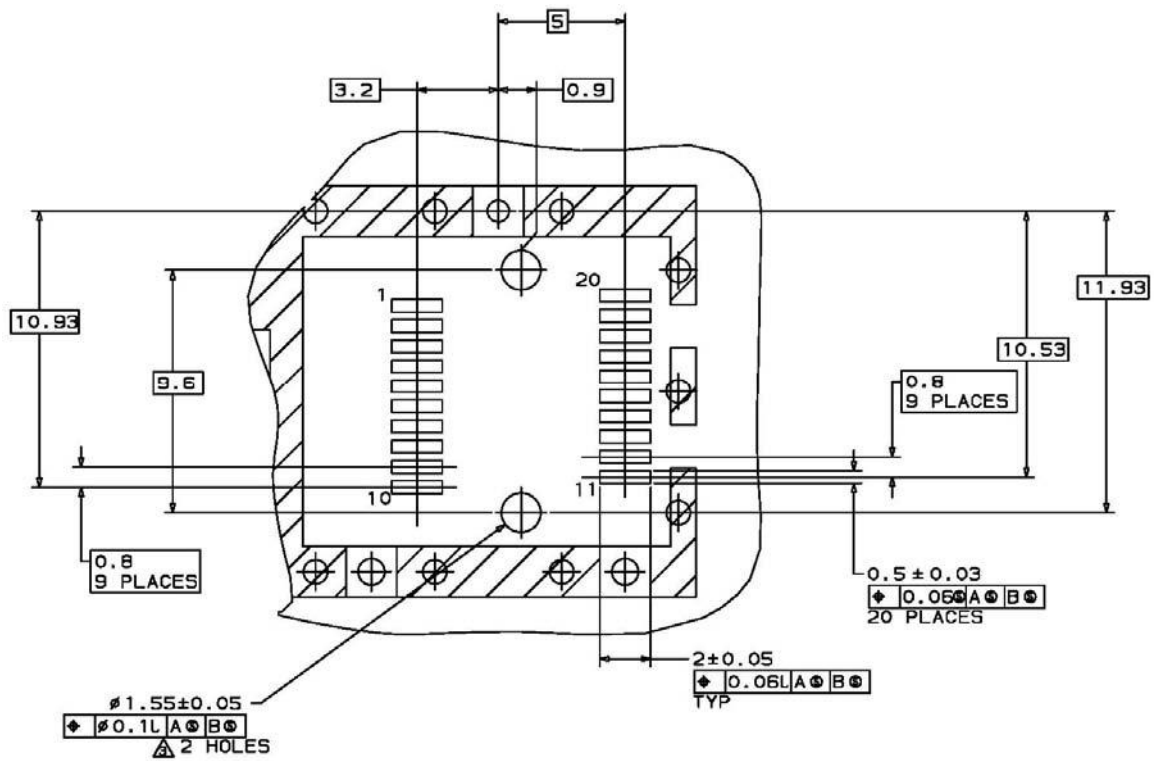

با افتخار ساخت ایران

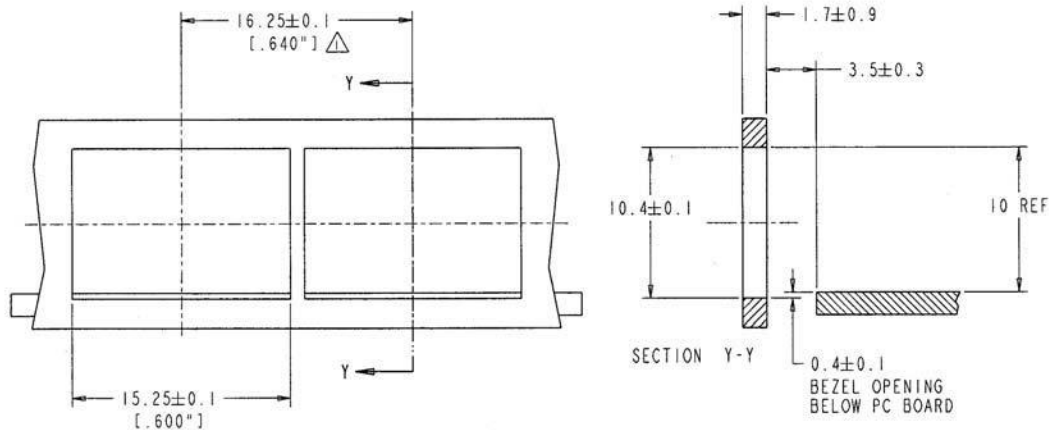

NOTES:

△ MINIMUM PITCH ILLUSTRATED, ENGLISH DIMENSIONS ARE FOR REFERENCE ONLY

2. NOT RECOMMENDED FOR PCI EXPANSION CARD APPLICATIONS